

Hustler Z Bac Vac Parts Manual

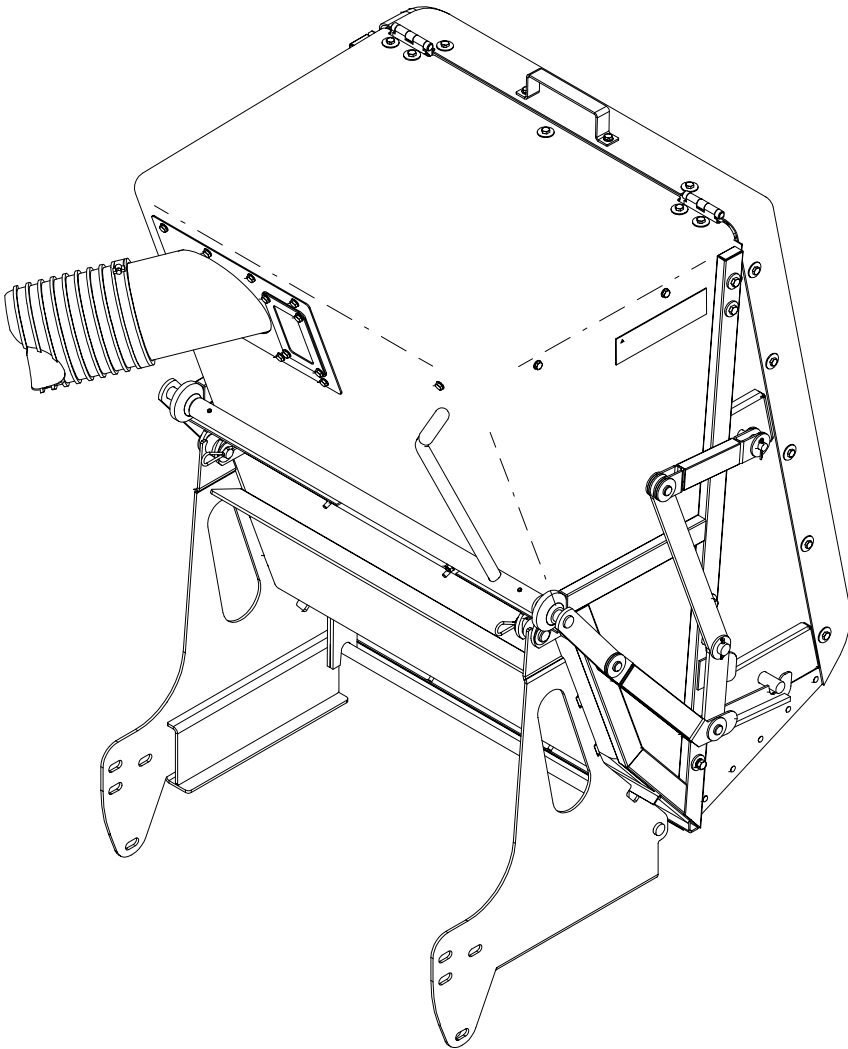

HUSTLER®

•••••

Hustler Turf Equipment

••••

P.O. Box 7000

•••

Hesston, Kansas

•

67062-2097

Table of Contents

Chapter 1

General Information 1-1

Chapter 2 Contents

Hopper Front Assembly 2-2

Door Assembly 2-4

Hopper Assembly 353219..... 2-6

Chapter 3 Contents

Blower Assembly 544510 3-2

Transition Chute Assembly 544510 3-4

Spindle Housing Assembly 520627 3-6

Chapter 4 Contents

Blower Installation, 72" Deck 4-2

Blower Installation, 60" Deck 4-4

Blower Installation, 52" Deck 4-6

Bac-Vac Installation 4-8

Weight Installation..... 4-10

Index i-1

Chapter 1

General Information

This Manual covers **353177K** Hustler Z Bac Vac for 52" Deck, **353185K** Hustler Z Bac Vac for 60" Deck, **357582K** Hustler Z Bac Vac for 72" Deck, **926337** Hustler Z Bac Vac Assembly, **353193** Hustler Z 52" Deck Adapter Kit, **353201** Hustler Z 60" Deck Adapter Kit, and **325084** Hustler Z 72" Deck Adapter Kit.

Service Literature

PART NO.	DESCRIPTION
353318	Owner's Manual
353326	Parts Manual

Note: When ordering parts, you must use the part number as shown for each part, not the index number. Always give the model and serial number to your parts and service representative.

Note: Items sold in bulk such as seals and hoses are sold by the foot.

Using this manual

Illustrations used were current at the time of printing, but subsequent production changes may cause your machine to vary slightly in detail. Excel Industries, Inc. reserves the right to redesign and change the machine as deemed necessary, without notification. If a change has been made to your machine which is not reflected in this parts manual, see your Hustler dealer for current information and parts.

Hardware Description Codes & Abbreviations

The following codes are used throughout this parts manual. Refer to this list when ordering parts.

ABBREVIATION	DESCRIPTION
CB	Carriage Bolt
CE	Clevis Pin
CP	Cotter Pin
CS	Cap Screw
CW	Cup Washer
FDRW	Fender Washer
FW	Flat Washer
HX	Hex Head
LW	Lock Washer
MB	Machine Bushing
MS	Machine Screw
NT	Nut
SC	Self Tapping Cap Screw
SH	Socket Head
SB	Shoulder Bolt
SS	Set Screw
OD	Outside Diameter
ID	Inside Diameter

Standard Torques

The following chart lists the standard torque values for the threaded fasteners found in this manual. Torque all cap screws, nuts and set screws to these values unless a different torque is shown in the Notes section next to the fastener

SIZE	FT-LBS	NM	SIZE	FT-LBS	NM
.250	8.2	11.1	M3	1	1.3
.312	17	23	M4	2.2	3
.375	30	40	M5	4.5	6.1
.438	48	65	M6	7.7	10.4
.500	73	99	M8	18.5	25
.562	105	143	M10	37	50
.625	145	200	M12	64	87
.750	260	350	M16	160	215
.875	420	565	M20	320	435
1.00	625	850	M24	555	750

NOTE:

Lubricate all grease zerks.

Chapter 2 Contents

Hopper Front Assembly	2-2
Door Assembly	2-4
Hopper Assembly 353219	2-6

Hopper Front Assembly

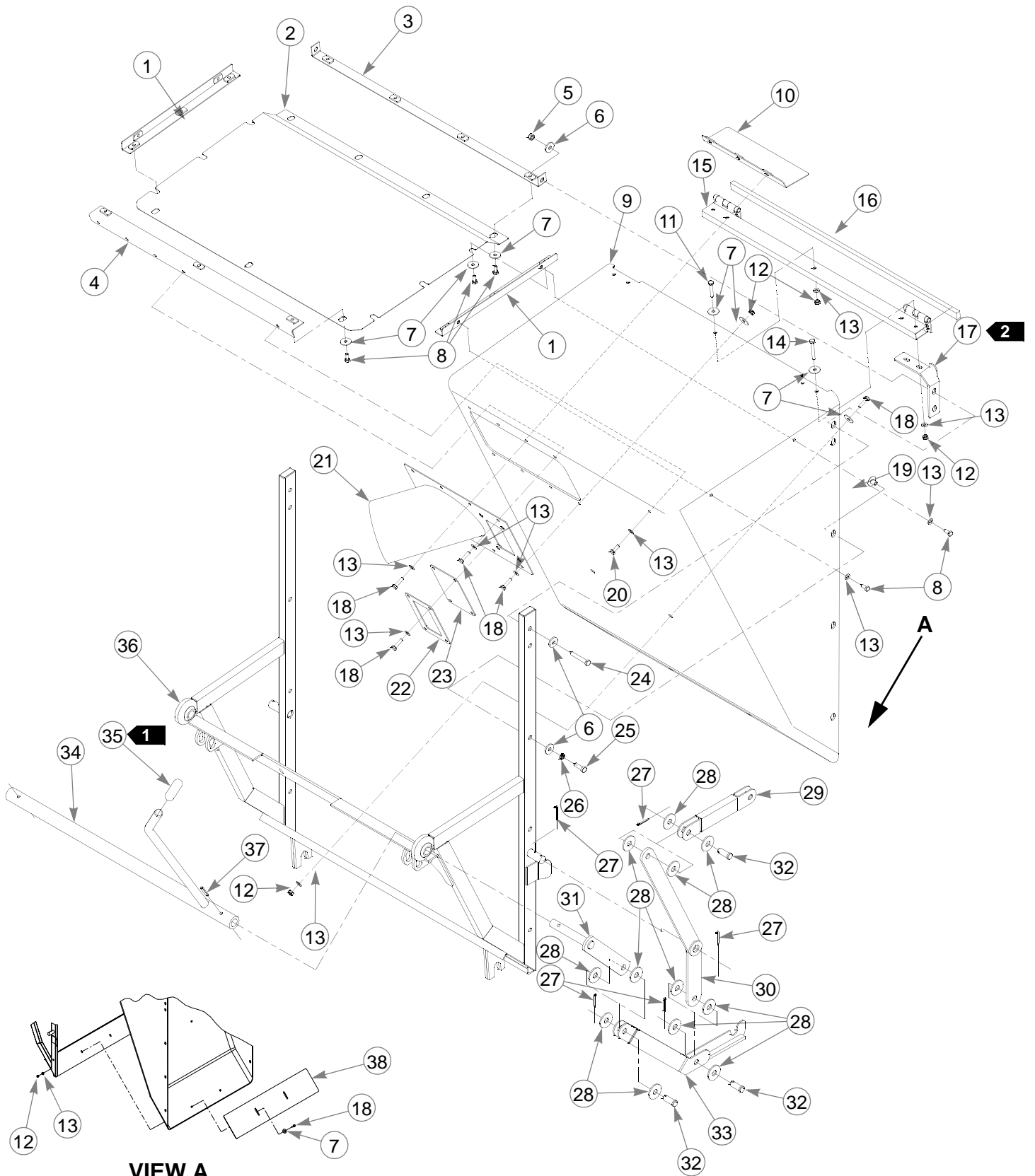

Hopper Front Assembly

INDEX NO.	SERVICE PART NO.	MFG. PART NO.	QTY.	DESCRIPTION
1	300871	300871	2	SIDE MOUNTING SCREEN ANGLE
2	300822	300822	1	HOPPER SCREEN
3	300897	300897	1	HOPPER SCREEN STRAP
4	300863	300863	1	REAR MOUNTING SCREEN ANGLE
5	058776	058776	4	NT .312-18 HX NL ZN
6	712927	712927	14	FW .344 X 1.00 X.12 HRD ZN
7	704304	704304	26	FDW 1.00 X .281 X .06 ZN
8	064329	064329	17	CS .25-20 X .625 HX G5 ZN
9	757278	757278	1	FIBERGLASS HOPPER
10	301119	301119	1	SPOUT DEFLECTOR
11	008581	008581	1	CS .250-20X1.500 HX G5 ZN
12	068551	068551	13	NT .250-20 HX NL ZN
13	017079	017079	26	FW .250X .560X.04 SAE ZN
14	704163	704163	4	CS .250-20 X 2.00 HX G5 ZN
15	300848	300848	1	HINGE
16	737536	737536	1	SEAL .43 X .75 29" LONG
17	499327	499327	1	LH CORNER SUPPORT
	499319	499319	1	RH CORNER SUPPORT
18	056077	056077	16	CS .250-20 X 1.00 HX G5 ZN
19	758789	758789	6	NT .312-18 CAMTAINER FASTNER
20	055939	055939	1	CS .250-20 X .75 HX G5 ZN
21	499426	499426	1	SPOUT
22	301770	301770	1	WINDOW TRIM
23	760512	760512	1	OVERFLOW WINDOW
24	064345	064345	4	CS .312-18 X 2.00 HX G5 ZN
25	036236	036236	6	CS .312-18 X 1.00 HX G5 ZN
26	017004	017004	6	LW .312 MED SPRING ZN
27	011387	011387	10	CP .125D X 1.250 LG HML ZN
28	443549	443549	24	PIVOT BEARING DISC
29	496588	496588	2	DOOR LINKAGE
30	499459	499459	2	DOOR STRAP LINKAGE
31	496554	496554	1	LH PIVOT LINKAGE
	496547	496547	1	RH PIVOT LINKAGE
32	027714	027714	6	CE .500 X 1.25 .156 X 1.093 ZN
33	496562	496562	1	RH DOOR LATCH LINKAGE
	496570	496570	1	LH DOOR LATCH LINKAGE
34	347765	347765	1	HANDLE
35	758854	758854	1	UV .75 ID X 5" LG BLACK GRIP
36	496513	496513	1	BAC VAC FRAME
37	758631	758631	2	RP .250 X 1.375 HEAVY SPIRAL
38	374843	374843	1	CLOSE OUT PLATE

NOTES:

1. Glue with 750265 Scotch Grip Plastic Adhesive.
2. Adjust both corner supports to the upper corners and tighten top bolts on hinge first then side bolts.

Door Assembly

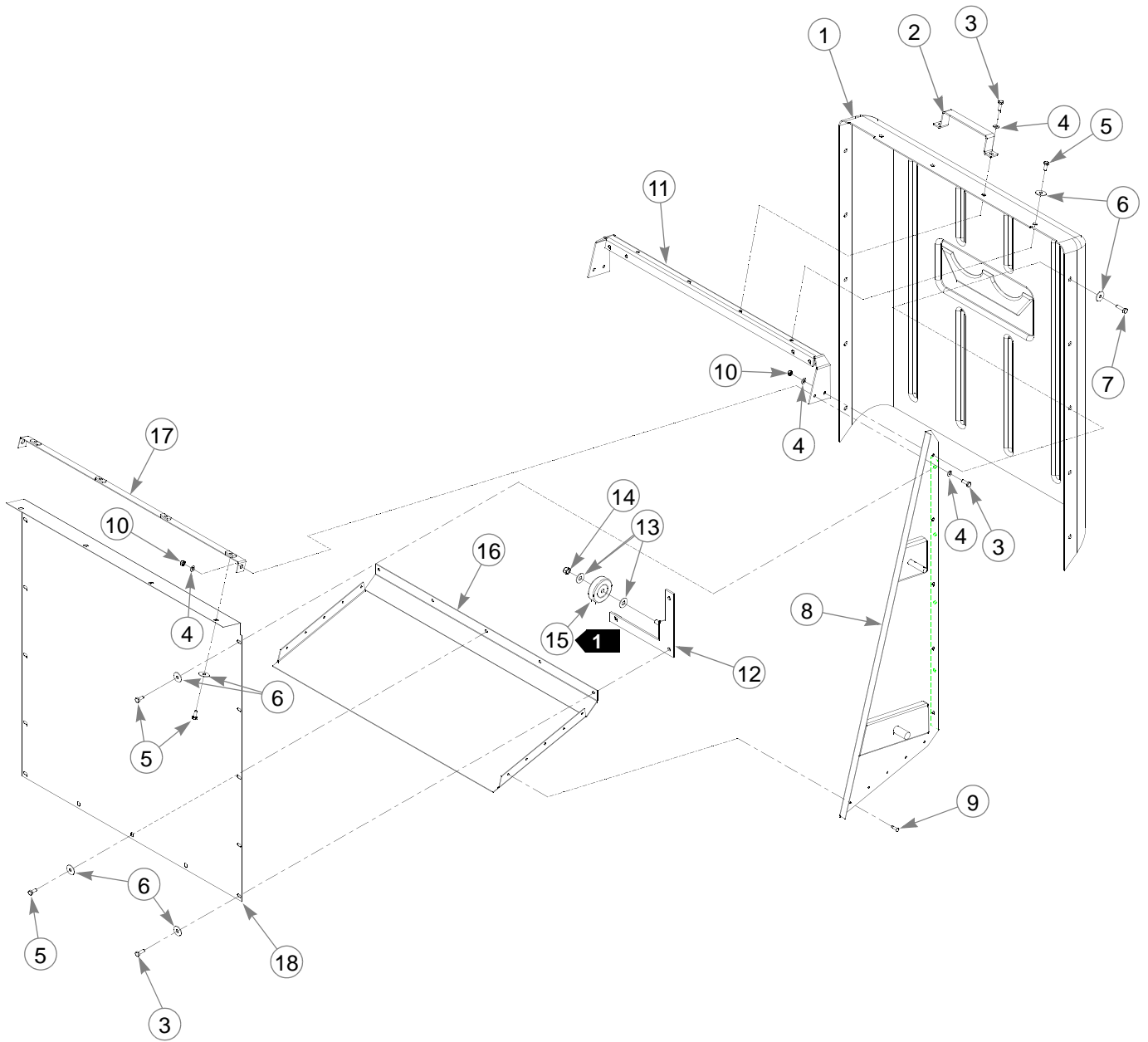

Door Assembly

INDEX NO.	SERVICE PART NO.	MFG. PART NO.	QTY.	DESCRIPTION
1	496232	496232	1	REAR DOOR COVER
2	301101	301101	1	HANDLE
3	055939	055939	10	CS .250-20 X .750 H X G5 ZN
4	017079	017079	8	FW .250 X .560 X .04 SAE ZN
5	064329	064329	21	CS .250-20 X .625 HX G5 ZN
6	704304	704304	29	FDW 1.000 X .281 X .06 ZN
7	056077	056077	2	CS .250-20 X1.000 HX G5 ZN
8	499301	499301	1	LH DOOR
	499293	499293	1	RH DOOR
9	760140	760140	10	RIVET .187 X .375 X .375 HD DIA
10	068551	068551	4	NT .250-20 HX NL ZN
11	499400	499400	1	DOOR CHANNEL
12	301036	301036	1	LH WHEEL BRACKET
	301028	301028	1	RH WHEEL BRACKET
13	076422	076422	4	FW .406 X 1.000 X .06 ZN
14	086660	086660	2	NT .375-16 HX LK NY
15	760181	760181	2	2.5X.75 3/8 BORE GRAY WHEEL
16	300855	300855	1	BOTTOM PLATE
17	300889	300889	1	DOOR SCREEN STRAP
18	300814	300814	1	DOOR SCREEN

NOTES:

1. Wheel to turn freely.

Hopper Assembly 353219

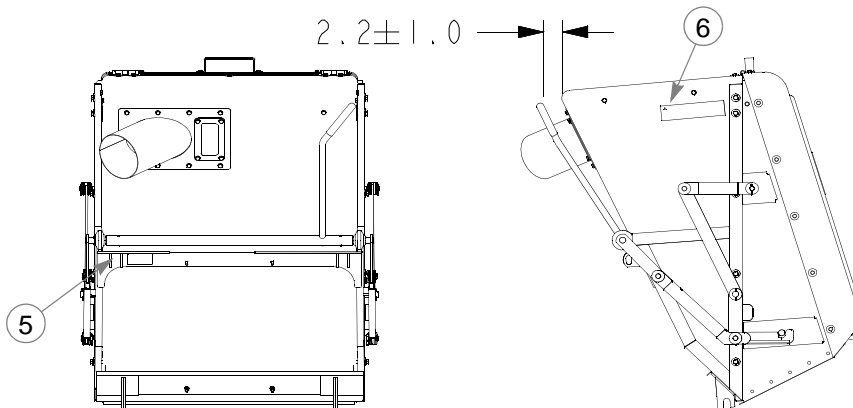
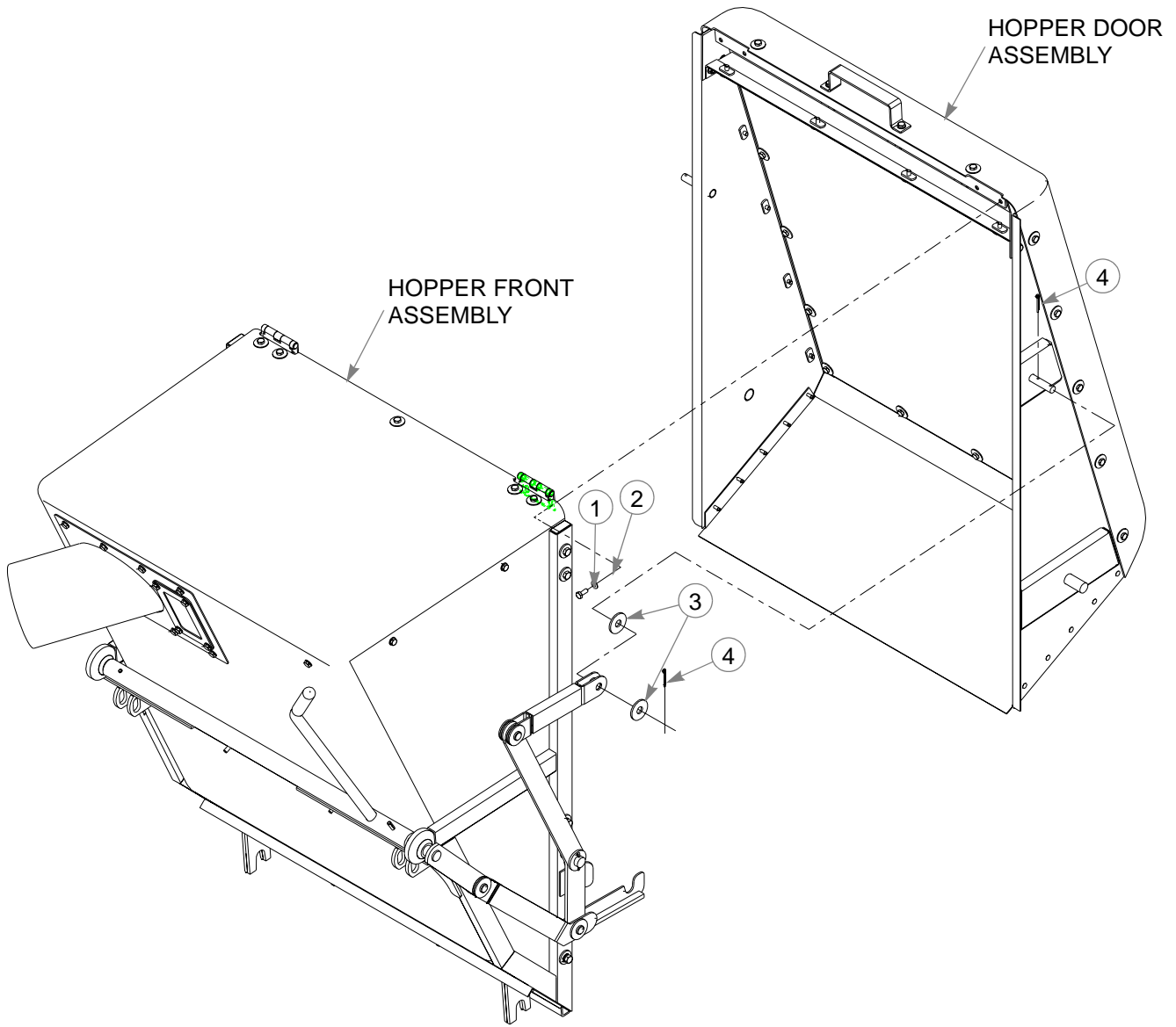

Hopper Assembly 353219

INDEX NO.	SERVICE PART NO.	MFG. PART NO.	QTY.	DESCRIPTION
1	064329	064329	4	CS .250-20 X .625 HX G5 ZN
2	017079	017079	4	FW .250 X .560 X.04 SAE ZN
3	443549	443549	4	PIVOT BEARING DISC
4	011387	011387	4	CP .125D X 1.250 LG HML ZN
5	741264	741264	1	MADE IN U.S.A.-COMBO DECAL
6	758532	758532	2	BAC VAC ID DECAL

NOTES:

1. Door to be flush with top surface of hopper assembly. Adjust door until sides align evenly with hopper. If needed, continue to adjust door until door assembly rests against the hopper in the closed position. Finish installing linkage.
2. Rotate handle several times to ensure proper opening and closing of door assembly, adjust as required.
3. Adjust 374843 (Close Out Plate) to close gap between front assembly and door assembly see "Hopper Front Assembly" on page 2-2

Chapter 3 Contents

Blower Assembly 544510	3-2
Transition Chute Assembly 544510.....	3-4
Spindle Assembly 520627	3-6

Blower Assembly 544510

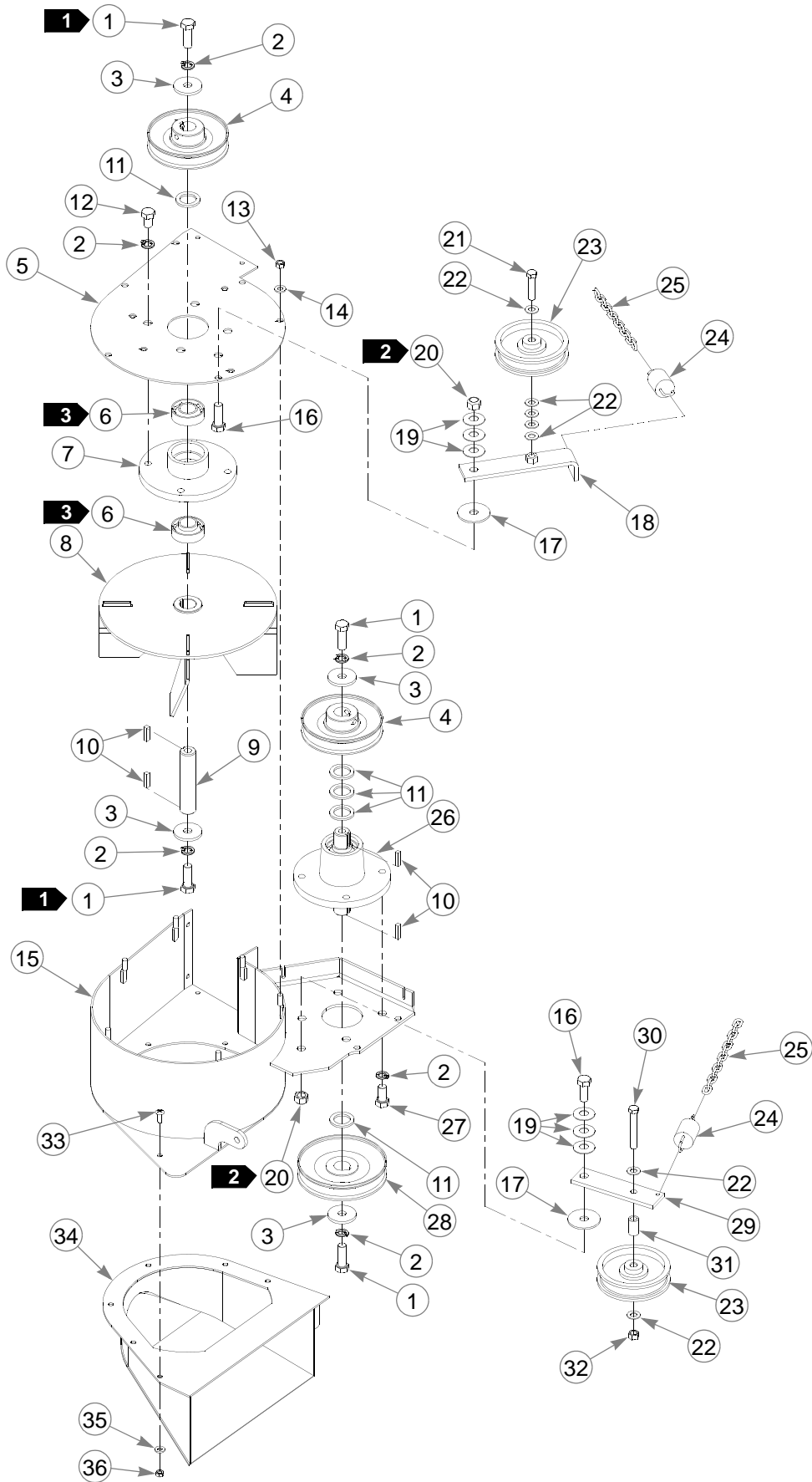

Blower Assembly 544510

INDEX NO.	SERVICE PART NO.	MFG PART NO.	QTY.	DESCRIPTION
1	078378	078378	4	CS .50-20 X 1.50 HX G5 ZN
2	017046	017046	12	LW .50 MEDIUM SPRING ZN
3	078386	078386	4	FW .510 X 1.750 X .180 ZN
4	301267	301267	2	DRIVE PULLEY
5	324327	324327	1	BLOWER TOP
6	077123	077123	2	BEARING W/O COLLAR
7	022582	022582	1	CAST SPINDLE HOUSING
8	758565	758565	1	IMPELLER 11"
9	758730	758730	1	JACK SHAFT
10	212472	212472	4	KEY
11	045765	045765	5	FW 1.030 X 1.50 X .134 ZN
12	705194	705194	4	CS .50-13 X .750 HX G5 ZN
13	034272	034272	6	NT .312-18 HX G5 ZN
14	768523	768523	6	FW .343 X .687 X .051/.080 HD ZN
15	324319	324319	1	BLOWER HOUSING
16	074252	074252	2	CS .50-13 X 1.50 HX G5 ZN
17	263517	263517	2	BEARING DISK
18	324343	324343	1	UPPER IDLER ARM
19	068759	068759	6	CW .560 X 1.340 X .050 PN
20	023317	023317	2	NT .50-13 UNT LK G5 ZN
21	705178	705178	1	CS .375-16 X 1.750 HX G5 ZN
22	767954	767954	7	FW .406 X .812 X .060 SAE HRD ZN
23	022772	022772	2	FLAT IDLER PULLEY
24	036384	036384	2	SPRING 1/4 COIL PL 1.23
25	259812	259812	2	DECK LIFT SPRING CHAIN
26	520627	426296	1	SPINDLE HOUSING ASSEMBLY
27	016527	016527	4	CS .50-13 X 1.00 HX G5 ZN
28	301317	301317	1	PULLEY
29	324293	324293	1	LOWER IDLER ARM
30	705731	705731	1	CS .375-16 X 2.750 G5 ZN
31	324350	324350	1	IDLER SPACER
32	054502	054502	1	NT .375-16 HX G5 ZN
33	079194	079194	6	MS .25-20 X .750 TH CR ZN
34	324335	324335	1	BLOWER INLET
35	768515	768515	6	FW .281 X .625 X .051/.080 HD ZN
36	024927	024927	6	NT .25-20 HX G5 ZN

NOTES:

1. Torque bottom bolt to 65 ft. lbs. first then torque top bolt to 65 ft. lbs.
2. Tighten to snug up assembly and still allow idler to rotate. Apply Loctite® 242.
3. Assemble bearings in spindle housing with extended race to the inside.

Transition Chute Assembly 544510

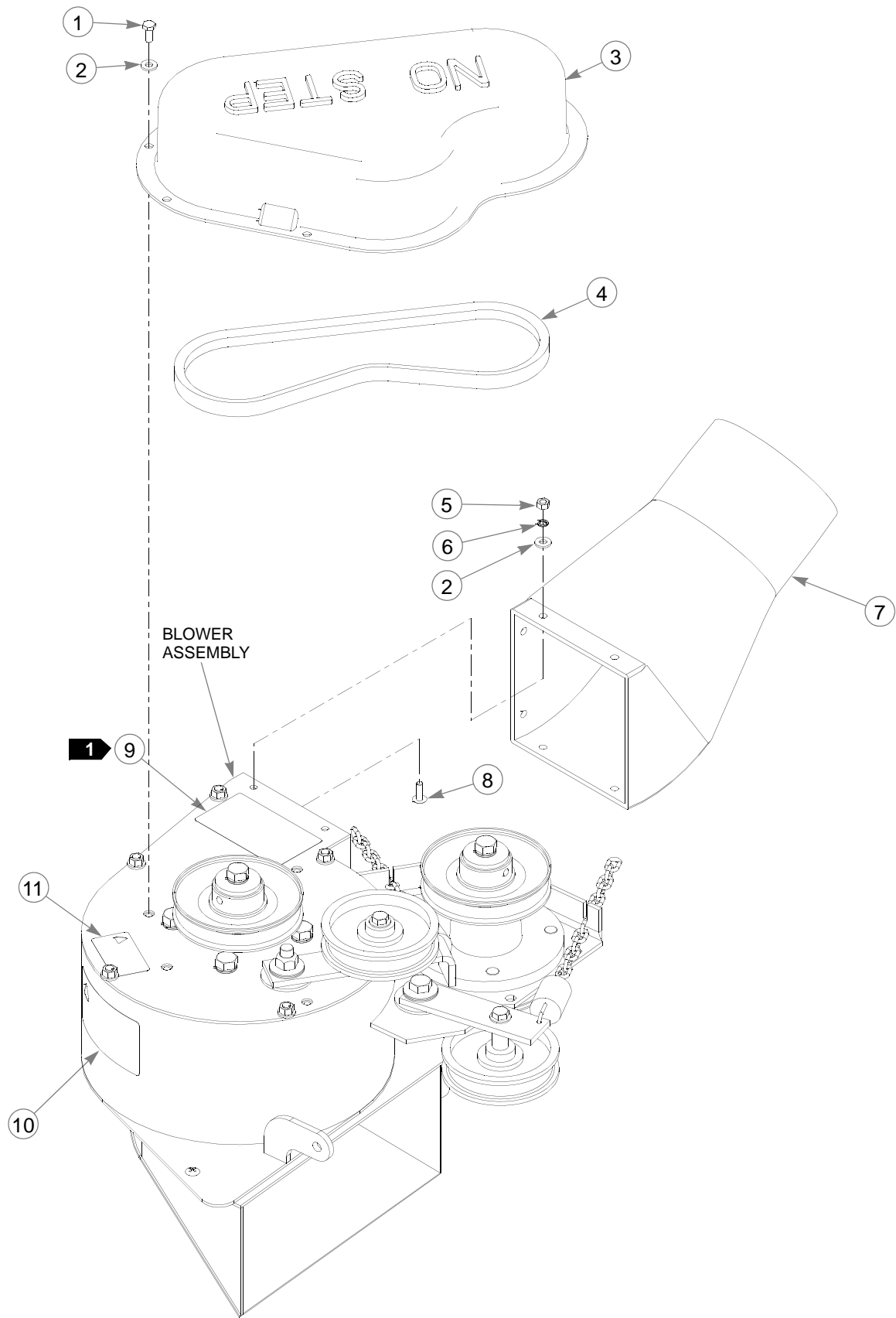

Transition Chute Assembly 544510

INDEX NO.	SERVICE PART NO.	MFG PART NO.	QTY.	DESCRIPTION
1	064329	064329	4	CS .25-20 X .625 HX G5 ZN
2	768515	768515	10	FW .281 X .627 X .051/.080 HD ZN
3	770180	770180	1	PULLEY COVER
4	770404	770404	1	UPPER BLOWER BELT
5	024927	024927	6	NT .25-20 HX G5 ZN
6	017038	017038	6	LW .25 MEDIUM SPRING ZN
7	757245	757245	1	TRANSITION CHUTE
8	079194	079194	6	MS .25-20 X .750 TH CR ZN
9	767012	767012	1	DANGER BLOWER DECAL
10	727453	727453	1	BELT & PULLEY DECAL
11	727438	727438	1	WHIRLING BLADES DECAL

NOTES:

1. Decal to be readable from blower outlet (hose) side.

Spindle Housing Assembly 520627

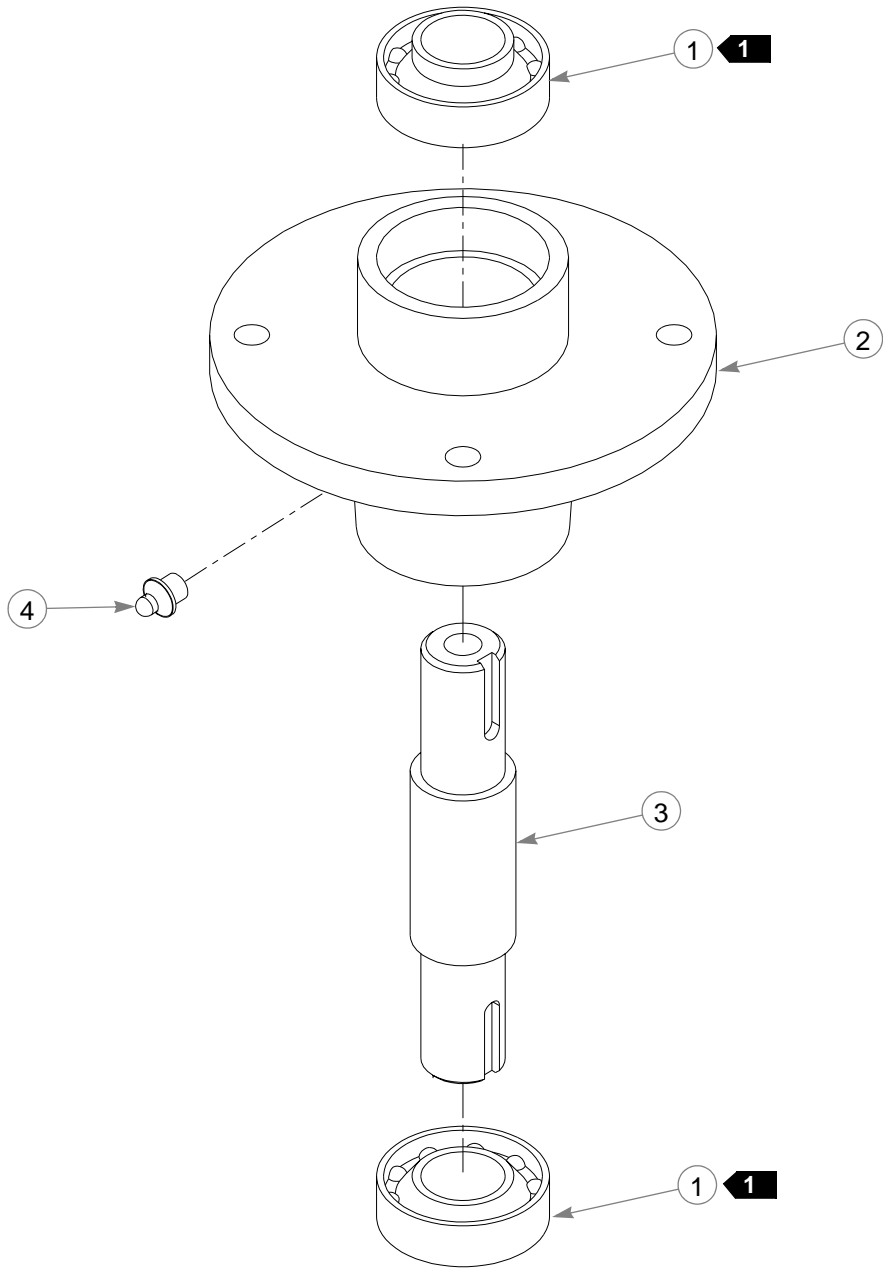

Spindle Housing Assembly 520627

ITEM NO.	SERVICE PART NO.	MFG. PART NO.	QTY	DESCRIPTION
1	077123	N/A	2	BEARING W/O COLLAR
2	034843	N/A	1	CAST SPINDLE HOUSING
3	008805	N/A	1	SPINDLE SHAFT
4	012005	N/A	1	GREASE FITTING

NOTES:

1. Install upper bearing with extended inner race up and lower bearing with extended inner race down.

Chapter 4 Contents

Blower Installation, 72" Deck	2-2
Blower Installation, 60" Deck	2-4
Blower Installation, 52" Deck	2-6
Bac Vac Installation	2-8
Weight Installation	2-10

Blower Installation, 72" Deck

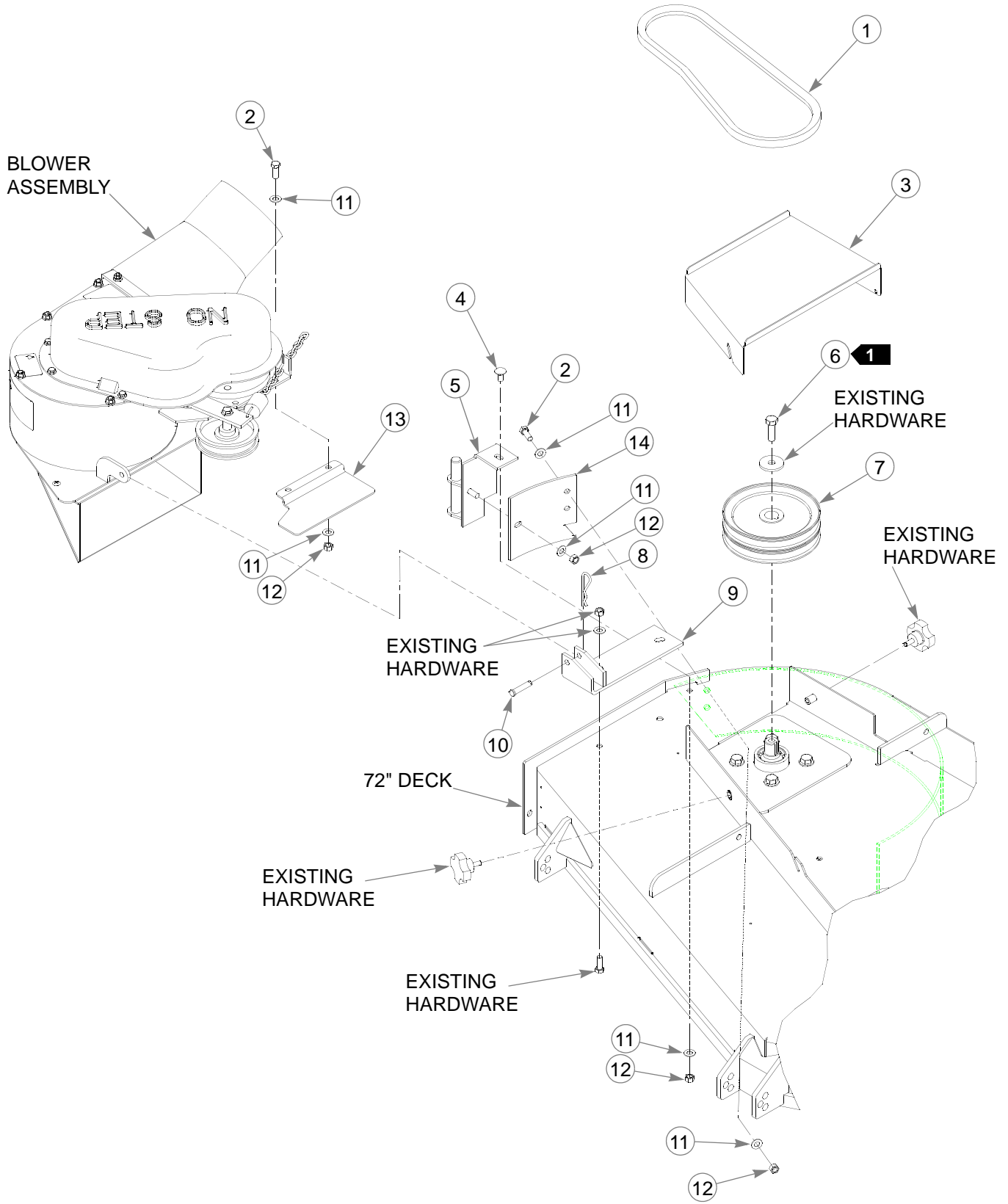

Blower Installation, 72" Deck

INDEX NO.	SERVICE PART NO.	MFG. PART NO.	QTY.	DESCRIPTION
1	770412	770412	1	LOWER BLOWER BELT
2	036244	036244	2	CS .375-16 X 1.00 HX G5 ZNYC
3	365163	365163	1	PULLEY COVER
4	011320	011320	1	CB .375-16 X .750 STD ZN
5	324301	324301	1	BLOWER PIVOT MOUNT
6	078378	078378	1	CS .500-13 X 1.500 HX G5 ZNYC
7	770388	770388	1	PULLEY
8	023036	023036	1	HP .148 X 2.690 ZN
9	324285	324285	1	BLOWER MOUNT
10	019471	019471	1	CE .380 X 1.75 .150 X 1.60 ZN
11	767954	767954	6	FW .406 X .812 X .060 SAE HD ZN
12	054502	054502	4	NT .375-16 HX GRD 5 ZN
13	325100	325100	1	LOWER BLOWER IDLER COVER
3 14	101089	101089	1	72" DISCHARGE ADAPTER

NOTES:

1. Torque to 65-75 ft. lbs.
2. All components are contained in 325084 Deck Adapter Kit for Hustler Z Bac Vac except 365163 (Pulley Cover) which is contained in 357582K.
3. Used on mowers with serial numbers after 05011098.

Blower Installation, 60" Deck

INDEX NO.	SERVICE PART NO.	MFG. PART NO.	QTY.	DESCRIPTION
1	770396	770396	1	LOWER BLOWER BELT
2	347468	347468	1	PULLEY COVER
3	011320	011320	1	CB .375-16 X .750 STD ZN
4	324301	324301	1	BLOWER PIVOT MOUNT
4	036244	036244	2	CS .375-16 X 1.00 HX G5 ZNYC
4	101071	101071	1	60" DISCHARGE ADAPTER
7	078378	078378	1	CS .500-20 X 1.500 HX G5 ZN
3	074252	074252	1	CS .500-13 X 1.500 HX G5 ZNYC
8	524785	524785	1	PULLEY
9	023036	023036	1	HP .148 X 2.690 ZN
10	324285	324285	1	BLOWER MOUNT
11	019471	019471	1	CE .380 X 1.75 .150 X 1.60 ZN
12	767954	767954	2	FW .406 X .812 X .060 SAE HD ZN
13	054502	054502	2	NT .375-16 HX GRD 5 ZN

NOTES:

1. Torque to 65-75 ft. lbs.
2. All components are contained in 353201 Deck Adapter Kit for Hustler Z Bac Vac , except 347468 (Pulley Cover) which is contained in 353201.
3. Use on deck with saddless spindle assemblies.
4. Used on mowers with serial numbers after 05011098.

Blower Installation, 52" Deck

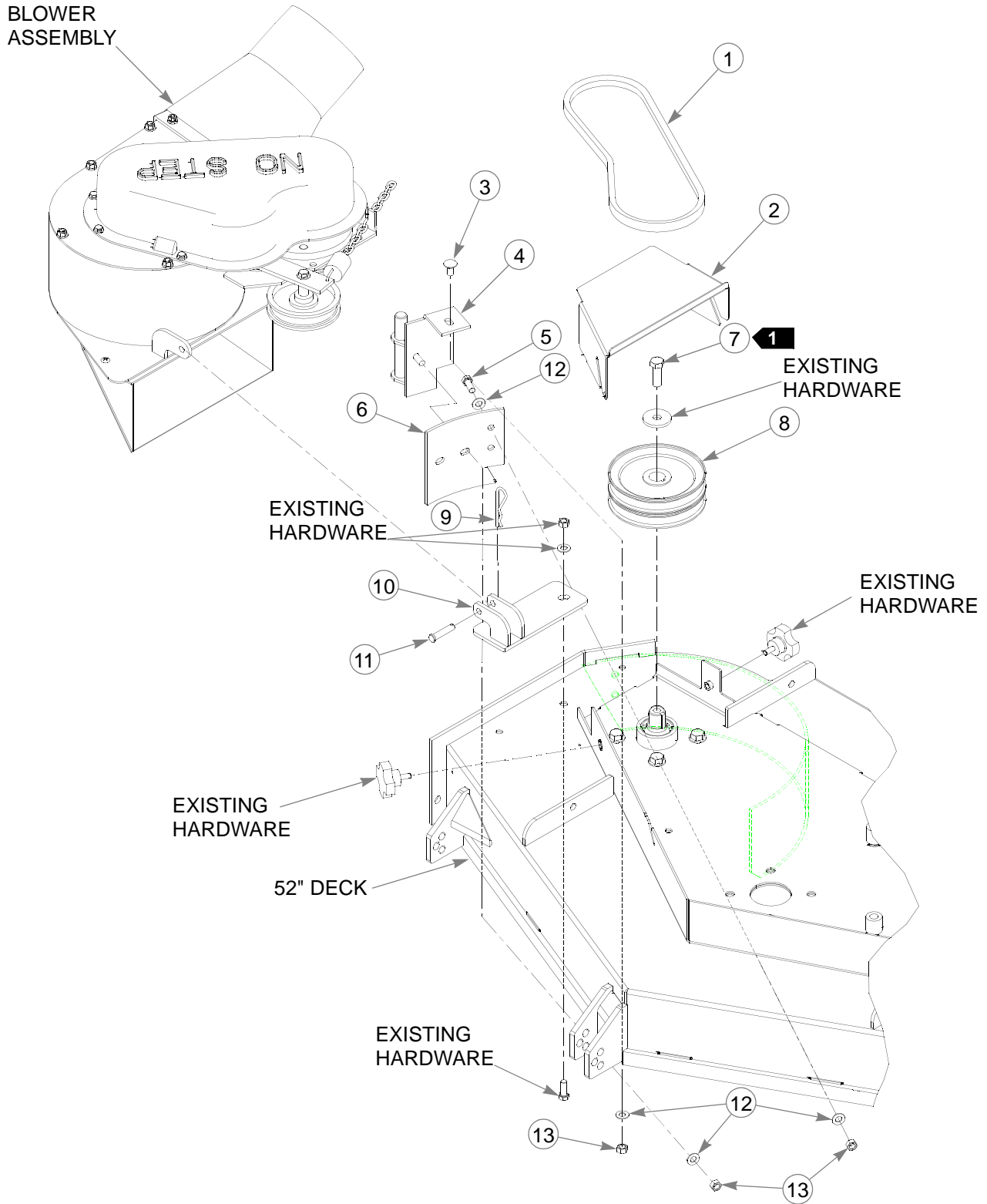

Blower Installation, 52" Deck

INDEX NO.	SERVICE PART NO.	MFG. PART NO.	QTY.	DESCRIPTION
1	782565	782565	1	LOWER BLOWER BELT
2	353367	353367	1	PULLEY COVER
3	011320	011320	1	CB .375-16 X .750 STD ZN
4	353011	353011	1	BLOWER PIVOT BRACKET
3	5	036244	2	CS .375-16 X 1.00 HX G5 ZNYC
3	6	352336	1	52" DISCHARGE ADAPTER
7	074252	074252	1	CS .500-13 X 1.500 HX G5 ZNYC
8	524785	524785	1	PULLEY
9	023036	023036	1	HP .148 X 2.690 ZN
10	353268	353268	1	BLOWER MOUNT
11	019471	019471	1	CE .380 X 1.75 .150 X 1.60 ZN
12	767954	767954	2	FW .406 X .812 X .060 SAE HD ZN
13	054502	054502	2	NT .375-16 HX GRD 5 ZN

NOTES;

-
1. Torque to 65 - 75 ft. lbs.
 2. All components are contained in 353193 Deck Adapter Kit for Hustler Z Bac Vac , except 353367 (Pulley Cover) which is contained in 353193.
 3. Used on mowers with serial numbers after 05011098.

Bac-Vac Installation

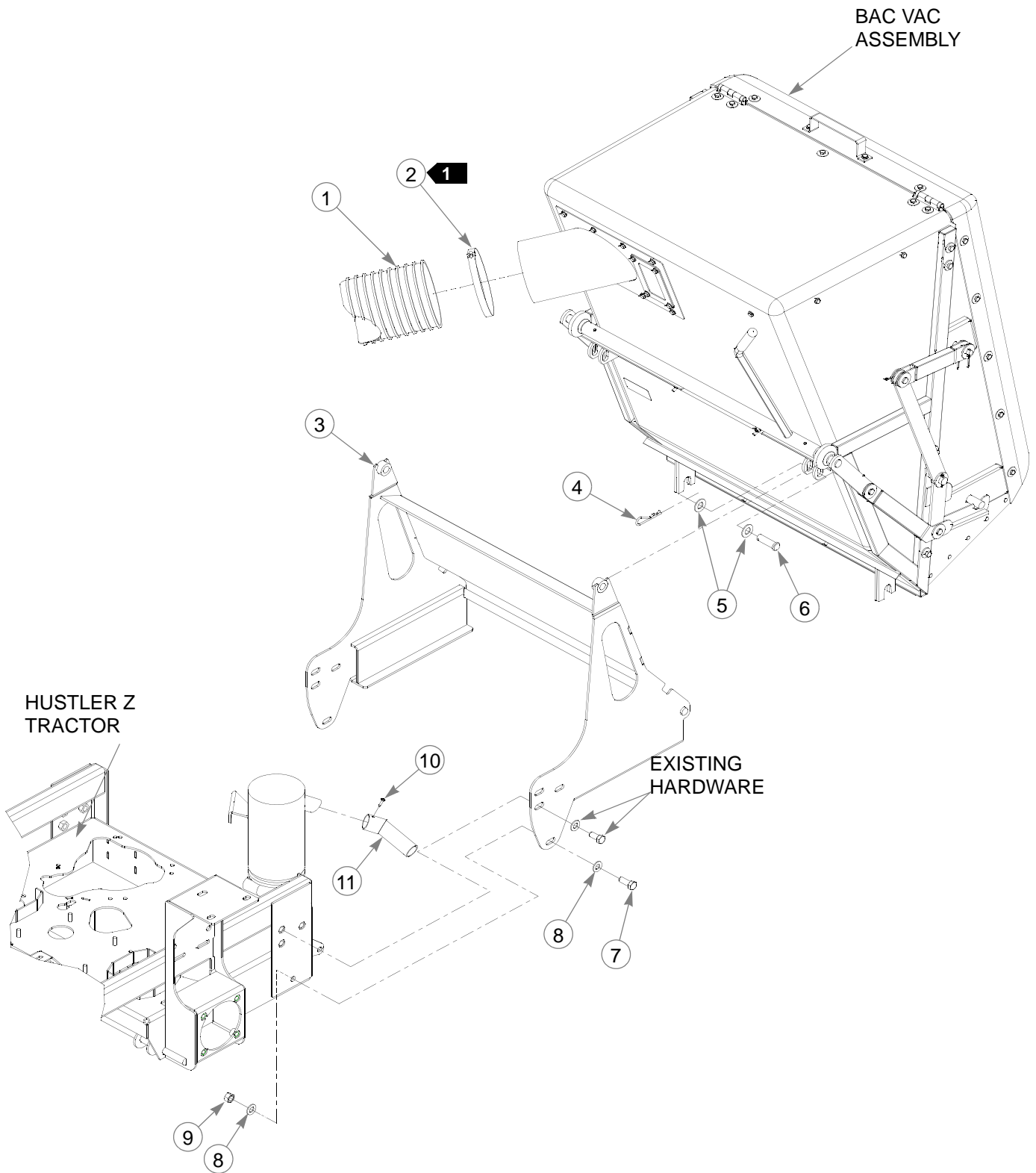

Bac-Vac Installation

INDEX NO.	SERVICE PART NO.	MFG. PART NO.	QTY.	DESCRIPTION
1	760306	760306	1	FLEXIBLE TRANSFER TUBE
2	022608	022608	2	HOSE CLAMP
3	373795	373795	1	MMZ BAC VAC MOUNT BRACKET
4	023036	023036	2	HP .148 X 2.690 ZN
5	728030	728030	4	FW .656 X 1.312 X .090 ZN
6	063560	063560	2	CE .625 X 2.00 .156 X 1.84 ZN
7	705954	705954	2	CS .500-13 X 1.25 HX G5 ZNYC
8	767962	767962	4	FW .531 X 1.063 X .090 SAE HD ZN
9	008193	008193	2	NT .500-13 HX G5 ZNYC
10	769299	769299	1	SC #10 X .750 PHILLIPS TYAB ZN
11	378760	378760	1	TAIL PIPE EXTENSION (HONDA/KAWASAKI)
	788919	788919	1	TAIL PIPE EXTENSION (27 KOHLER)

NOTES:

1. Second clamp is installed on Flexible Transfer Tube at Blower Outlet.

Weight Installation

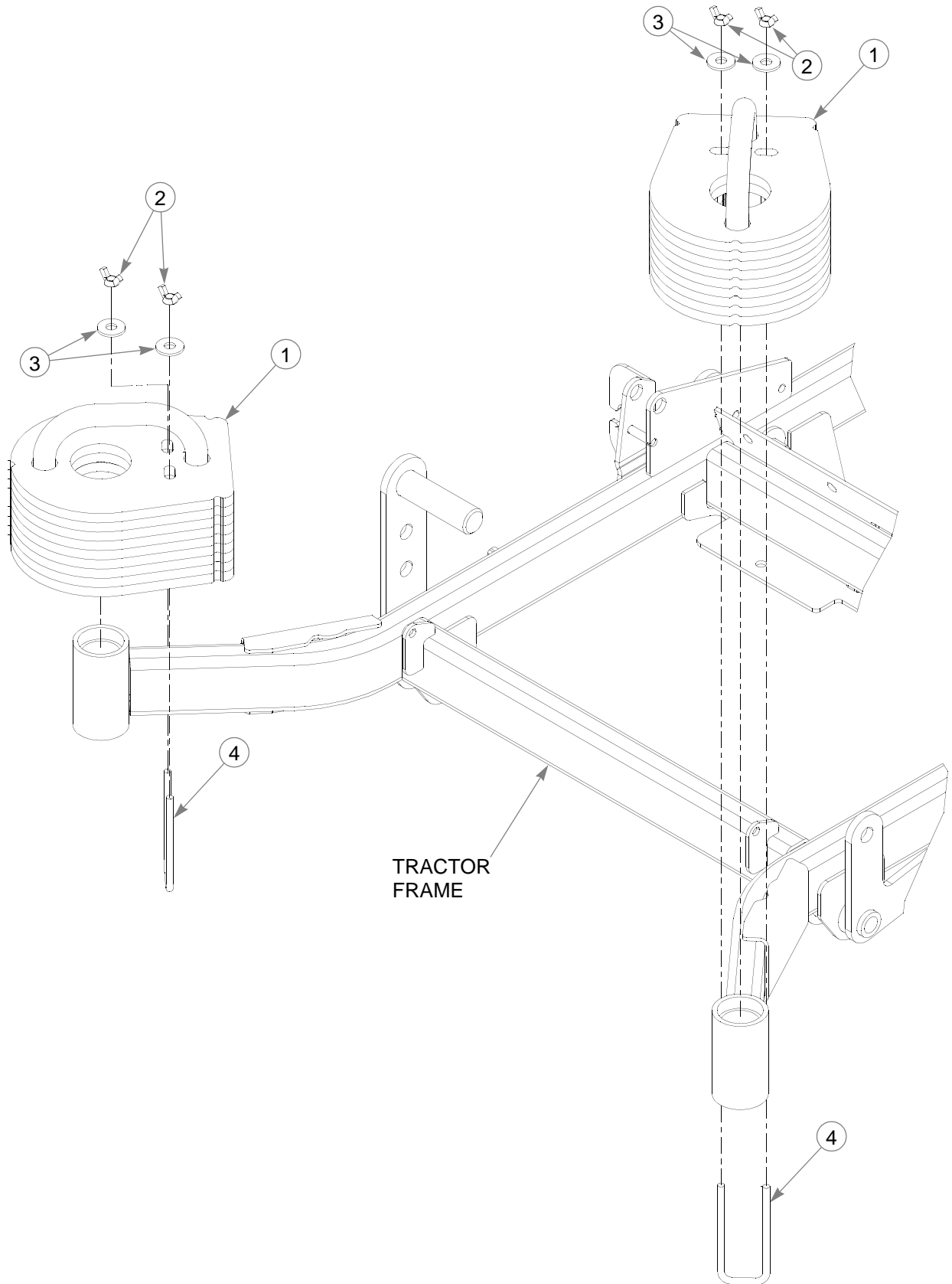

Weight Installation

INDEX NO.	SERVICE PART NO.	MFG. PART NO.	QTY.	DESCRIPTION
1	353243	353243	2	BAC VAC WEIGHT
2	722108	722108	4	WG NT .375-16 ZN
3	712893	712893	4	FW .406 X 1.25 X.12 HRD ZN
4	782599	782599	2	2.00 SQ BOTTOM 3/8-16 U-BOLT

NOTES:

Numerical Index

Part No.	Page No.	Part No.	Page No.	Part No.	Page No.
Index					
Numerics					
008193	4-9	300863	2-3	499319	2-3
008581	2-3	300871	2-3	499327	2-3
008805	3-7	300889	2-5	499400	2-5
011320	4-3, 4-5, 4-7	300897	2-3	499426	2-3
011387	2-3, 2-7	301028	2-5	499459	2-3
012005	3-7	301036	2-5	520627	3-3
016527	3-3	301101	2-5	524785	4-5, 4-7
017004	2-3	301119	2-3	704163	2-3
017038	3-5	301267	3-3	704304	2-3, 2-5
017046	3-3	301317	3-3	705178	3-3
017079	2-3, 2-5, 2-7	301770	2-3	705194	3-3
019471	4-3, 4-5, 4-7	324285	4-3, 4-5	705731	3-3
022582	3-3	324293	3-3	705954	4-9
022608	4-9	324301	4-3, 4-5	712893	4-11
022772	3-3	324319	3-3	712927	2-3
023036	4-3, 4-5, 4-7, 4-9	324327	3-3	722108	4-11
023317	3-3	324335	3-3	727438	3-5
024927	3-3, 3-5	324343	3-3	727453	3-5
027714	2-3	324350	3-3	728030	4-9
034272	3-3	325084	1-1, 4-3	737536	2-3
034843	3-7	325100	4-3	741264	2-7
036236	2-3	347468	4-5	750265	2-3
036244	4-3, 4-5, 4-7	347765	2-3	757245	3-5
036384	3-3	352336	4-7	757278	2-3
045765	3-3	353011	4-7	758532	2-7
054502	3-3, 4-3, 4-5, 4-7	353177K	1-1	758565	3-3
055939	2-3, 2-5	353185K	1-1	758631	2-3
056077	2-3, 2-5	353193	1-1, 4-7	758730	3-3
058776	2-3	353201	1-1, 4-5	758789	2-3
063560	4-9	353219	2-6, 2-7	758854	2-3
064329	2-3, 2-5, 2-7, 3-5	353243	4-11	760140	2-5
064345	2-3	353268	4-7	760181	2-5
068551	2-3, 2-5	353318	1-1	760306	4-9
068759	3-3	353326	1-1	760512	2-3
074252	3-3, 4-5, 4-7	353367	4-7	767012	3-5
076422	2-5	357582K	1-1, 4-3	767954	3-3, 4-3, 4-5, 4-7
077123	3-3, 3-7	365163	4-3	767962	4-9
078378	3-3, 4-3, 4-5	373795	4-9	768515	3-3, 3-5
078386	3-3	374843	2-3	768523	3-3
079194	3-3, 3-5	378760	4-9	769299	4-9
086660	2-5	426296	3-3	770180	3-5
101071	4-5	443549	2-3, 2-7	770388	4-3
101089	4-3	496232	2-5	770396	4-5
212472	3-3	496513	2-3	770404	3-5
259812	3-3	496547	2-3	770412	4-3
263517	3-3	496554	2-3	782565	4-7
300814	2-5	496562	2-3	782599	4-11
300822	2-3	496570	2-3	788919	4-9
300848	2-3	496588	2-3	926337	1-1
300855	2-5	499293	2-5		
		499301	2-5		